

PMMA FLOW CELL

Type: FC2.TL.*

Description

The flow cell enables the use of sensors in a flow through arrangement.

The flow arrangement is:

Thin layer cell "TL" for AC1, AC2, CC1, CC2 and CC3 sensors.

The sensor is inserted into the slit of cell and tightened by closing of the door. The cell ensures the flow around the working electrode and it is optimised so that no air bubbles cumulate in the cell. The cell contains also the contact and output cable.



Physical Parameters

Dimensions:

Weight:	11 gms
Length:	42 mm
Width:	24 mm
Thickness:	16 mm

Flow Arrangement - Thin layer cell "TL"

The dependence of current on flow is in Matsuda⁵

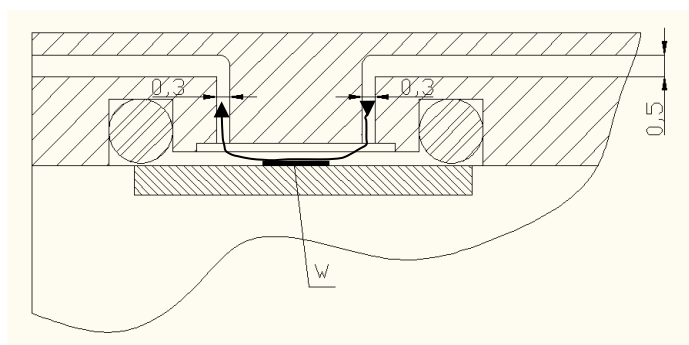

Cell Material

- Polymethylmethacrylate

Experimental Accessories

- Peristaltic Pump PP*.M
- Linear Pump LP

Cell Usage

- Flow measurement³
- Flow-injection analysis^{4,6}

References

1. J. Yamada, H. Matsuda, Limiting Diffusion currents in hydrodynamic voltammetry III. Wall jet electrodes, *Electroanalytical Chemistry and Interfacial Electrochemistry*, 44, 1973, 189-198
2. R. Dworak, H. Wendt, Hydrodynamics and Mass Transfer within the Cylindrical Capillary Gap Electrolysis Cell, *Berichte der Bunsen-Gesellschaft* 80 (1976) 77-82

3. J. Krejci, L. Jezova, R. Kucerova, R. Plicka, S. Broza, D. Krejci, The measurement of small flow, *Sensors and Actuators A* 266 (2017) 308-313
4. J. Krejci, R. Sejnohova, V. Hanak, H. Vranova, Screen Printed Electrodes with Improved Mass Transfer, *New perspectives in biosensors technology and applications* (2011) 291-311
5. Matsuda, H., *J. Electroanal. Chem.* 15, 325, (1967)
6. Růžička

Ordering Information

- The order is specified by whole product code
- Minimum order quantity - 1 flow cell
- Delivery time for standard FC2.TL cell is 4 weeks from receipt of order
- Delivery time for non-standard FC2.TL cell depends on final technical specification of order

Flow cell ordering formula

FC2.TL.* (Flow cell)

F - Flow	3 TRIAD - (Triad01 PalmInstruments)
C - Cell	3 LEMO4 - (4 pins PalmInstruments)
2 - Cell reference number (PMMA)	3 LEMO5 - (5 pins PalmInstruments)
TL - Thin layer	4 - BNC connectors
* - Termination	5 - Banana plugs (2 mm), 1.5 m cable
1 - Banana plugs (4 mm)	6 - Banana plugs (2 mm), 0.2 m cable
2 - 7 poles BVT connector	

Types of Termination (Three shielded core cable)

Model	Termination	Evaluating Units
FC2.TL.S	Single conductors	any device
FC2.TL.1	Banana plugs 4 mm	any device
FC2.TL.2	7 poles BVT connector	any device
FC2.TL.3 TRIAD	Triad01 PalmInstruments	Palmsens, EmStat2
FC2.TL.3 LEMO4	LEMO 4 pins PalmInstruments	Palmsens3, EIS, EmStat3, 3+
FC2.TL.3 LEMO5	LEMO 5 pins PalmInstruments	Palmsens4
FC2.TL.4	BNC connectors	any device
FC2.TL.5	Small banana plugs 2 mm	any device
FC2.TL.6	Small banana plugs 2 mm	BVT Electrochemical workstation any device

Warnings

The parts of device which are in contact with analyzed solutions are made from PMMA - polymethylmethacrylate. Some solution components can damage the device. Following solutions were proved to damage it:



- Organic solvents
- Solutions of HCl with tetraethyl orthosilicate causes induced creep of PMMA and metal parts corrosion.

Analyte conversion on AC1 electrochemical sensor using FC2.TL cell at different flow rates

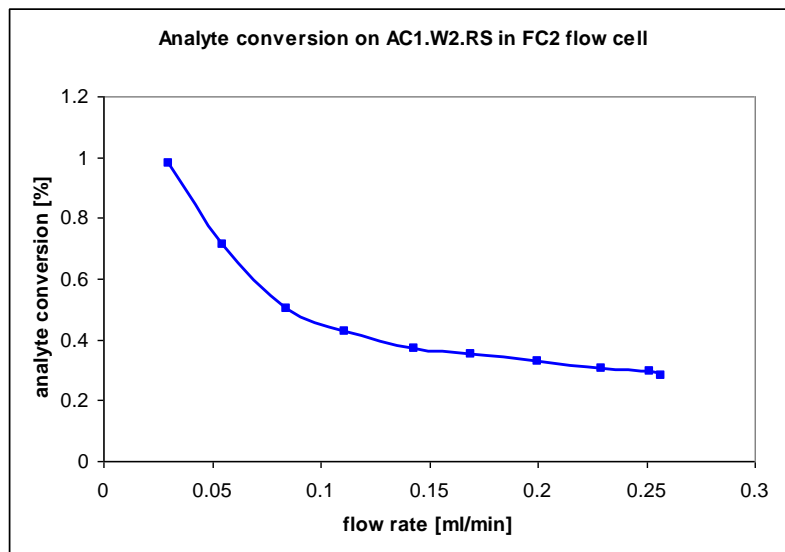

Example of Order

- 5 pieces - FC2.TL.1

Internal Wiring

FC2.TL.S

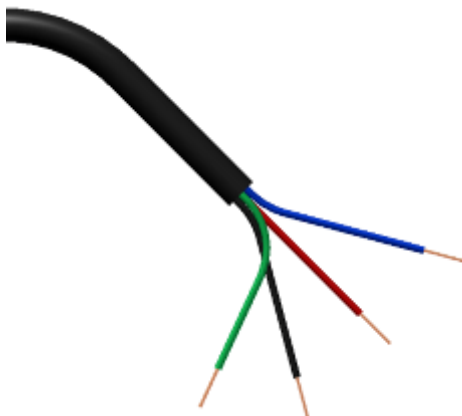

FC2.TL.1



FC2.TL.2



TRIAD

FC2.TL.3 TRIAD
 FC2.TL.3 LEMO4, FC2.TL.3 LEMO5



LEMO

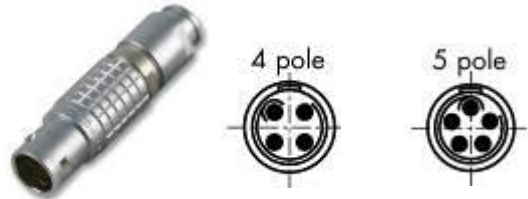

FC2. *.4

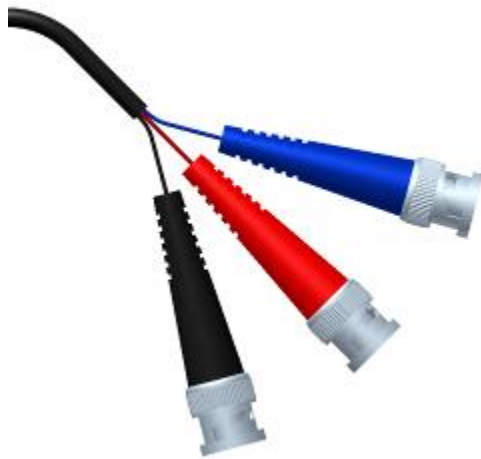

FC2. *.5

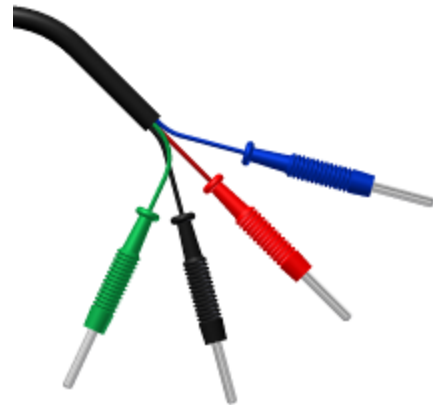

FC2. *.6

