

ELECTROCHEMICAL SENSOR

Type: AC2.W*.R* (*)

Description

The sensor is formed on a corundum ceramic base. On to this surface two working electrodes, and one reference electrode are applied. The working and the reference electrodes can be made of variety of materials. At the end of the sensor there is a contacting field which is connected with the active part by the silver conducting paths which are covered by a dielectric protection layer. Different bio-chemically active substance can be immobilised on the working electrode to create a biosensor.

Physical parameters

Dimensions:

Weight: 0.3 gms
Length: 25.40 mm
Width: 7.26 mm
Thickness: 0.63 mm

A = 4.00 mm
B = 2.54 mm
D_w = 1.00 mm

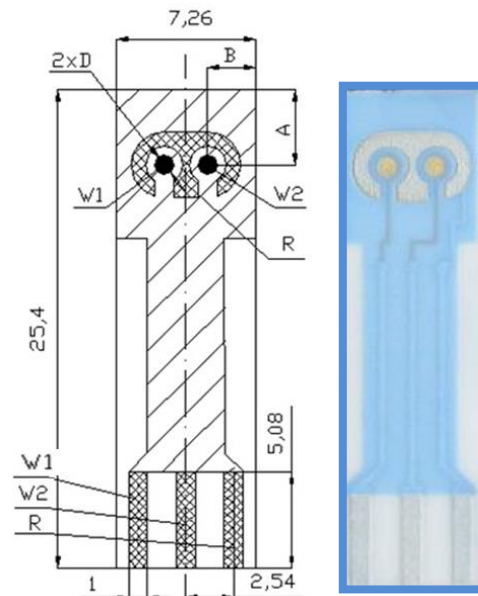

Electrode Materials are defined by:

AC2.W*.R* (*)

The asterisk is replaced by the appropriate number or letter.

| | |
|-----------------------------------------------------------------------------------|------------------------------------------|
| AC - Amperometric sensor or electrode on corundum ceramic base | |
| AC2 - Sensor group reference number | |
| W - Working electrode material | R - Reference electrode material |
| S - Alloy of Gold and Platinum | S - Silver |
| 1 - Pure Gold | 1 - Silver / Silver Chloride |
| 2 - Pure Platinum | 2 - Silver covered by AgCl |
| 3 - Pure Silver | (*) - Additional Technical specification |
| 4 - Carbon(Graphite) | H - Heating of the sensor |
| 5 - Manually Microdispensed Carbon(Graphite) with Au+Pt alloy auxiliary electrode | T - Temperature sensing element |

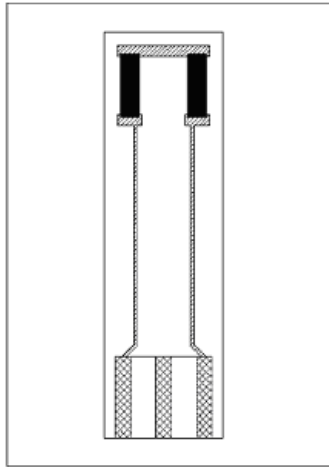

AC2.W*.R* (H)

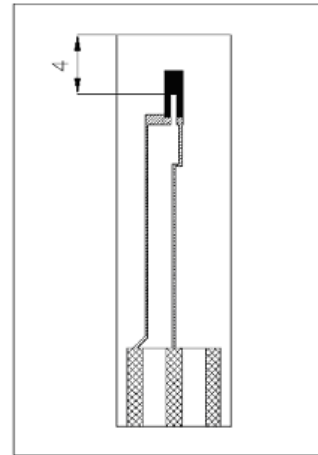

AC2.W*.R* (T)

Connector types for AC2 sensors range

| | KA2 | KA2.S | KA2.C | KA4 |
|---------------|-----|-------|-------|-----|
| AC2.W*.R* | ✓ | ✓ | ✓ | ✓ |
| AC2.W*.R*(H) | | | | ✓ |
| AC2.W*.R* (T) | | | | ✓ |

Heating parameters:

Maximum voltage is 35 V and temperature approximately 500°C, resistance: 80 Ohm.

Thermistor:

- 1) Resistance paste - resistance 160 Ohm, coefficient K= 6100 ppm/K
- 2) Pt1000

Sensor Usage

This specific range of AC2 sensors enable the measurement of:

- Basic electrochemical and bio-electrochemical techniques
- 2 species simultaneous
- Analyte on background of electrochemically active compound (electrochemical interference)

Activation

BVT offers unactivated versions of both W4 and W5 for standard tests and direct measuring. For specialised testing and more precise results it is recommended to have the W4 and W5 activated (the activation in most cases, is unique for each type of test being carried out). The activation can be carried out by BVT, based on your requirements (activation will have an additional cost, which varies based on the type of activation required).

(Note: Please refer to AC1.* Data Sheet for more information on Activation)

Ordering information

- The order is specified by whole sensor description formula
- Minimum order quantity - 20 sensors
- All order quantities are to be in multiples of 20 e.g. 20, 40, 80, etc.
- Delivery time for standard AC2 sensors is 4 weeks from receipt of order
- Delivery time for non-standard AC2 sensors depends on final technical specification of order

Examples of Order

- 100 pieces - AC2.W2.R1